



## HOW TO LOAD TRAILER FOR ZEBRA LIGHTWEIGHT AIRBAGS

1. Load first unit(s) tightly against the nose of the trailer.
2. Load each successive row TIGHTLY against the previous row.

**⚠ CAUTION ⚠ Plan the load so that the weight of the product is balanced from side to side within the trailer.**

**NOTE: The proper number and location of airbag(s) are determined by your specific application and can be obtained by contacting your Shippers representative.**

3. Only use the Shippers inflator kit and inflator tips.

**⚠ CAUTION ⚠ Read operating and safety instructions before using inflator kit.**

4. Position the airbag approximately 1" above the floor to keep it from rubbing in transit and remove all the wrinkles.

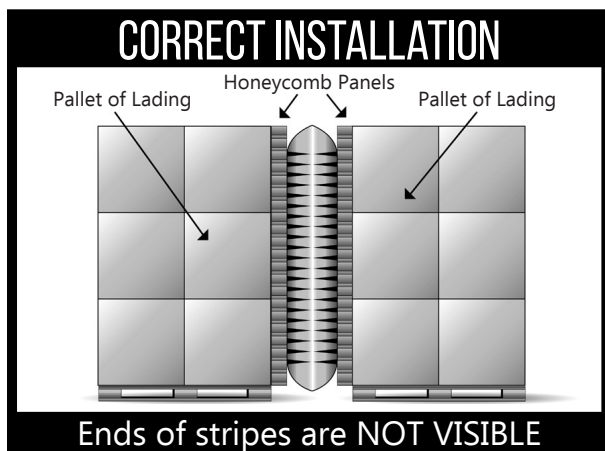
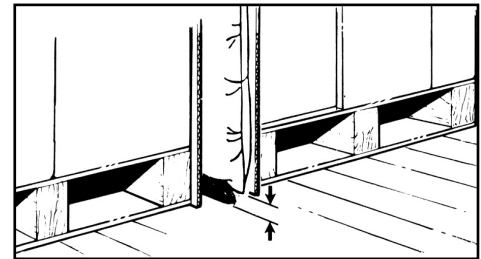
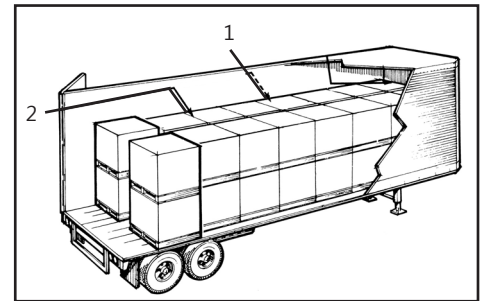

**Narrow the void whenever possible by:**

- Using honeycomb panels. (see above diagram)
- Turning the pallets (pinwheel) where the airbags are applied
- Contact your Shippers representative for other possible solutions

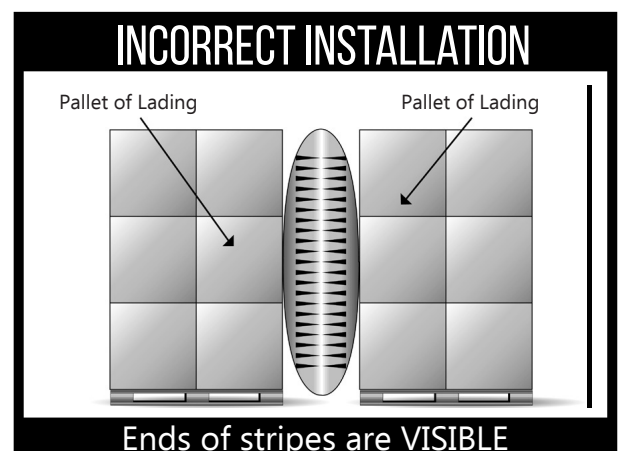

- NEVER inflate LEVEL 0 (Sewn-End [SE] and Abrasion-Resistant [AR]) Airbags over 2 PSI
- NEVER inflate LEVEL 1 airbags over 3 PSI
- Exceeding the maximum air pressure stated on the airbag may cause the bag to burst

## INFLATING ZEBRA LIGHTWEIGHT AIRBAGS

1. Set air compressor regulator to appropriate settings. Additional assistance is available from a Shippers representative.

**⚠ CAUTION ⚠ Please contact your Shippers representative to determine what the best PSI level is for your airbags.**

2. Unscrew valve cap and ensure that the blue flap is in the closed position.

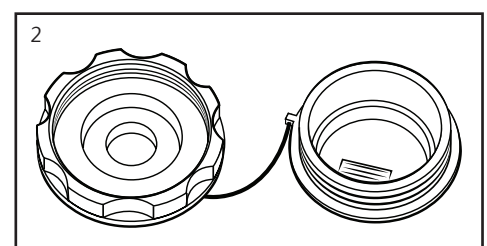

# INFLATING ZEBRA LIGHTWEIGHT AIRBAGS (CONTINUED)

3. Attach Super Flow™ Inflator to valve and squeeze inflator trigger to begin inflation.

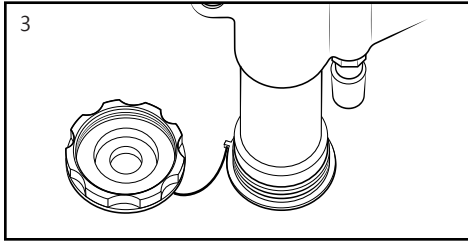

4. When air flows out the back of the inflator, the desired pressure has been achieved. Remove inflator and tightly secure valve cap.

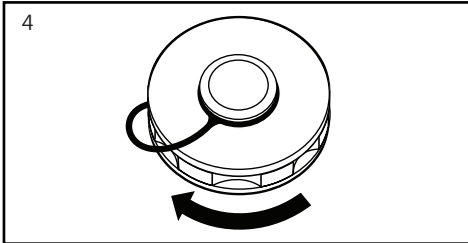

## SUPER FLOW™ OUTPUT PRESSURE

Input Pressure	SF1000 Standard Pressure	SF2000/SF3000 High Pressure
40 PSI	0.5	1.0
50 PSI	0.7	1.4
60 PSI	1.0	1.6
70 PSI	1.1	2.0
80 PSI	1.3	2.3
90 PSI	1.5	2.9
100 PSI	1.8	3.5*
110 PSI	2.0	4.0*
120 PSI	2.3	4.5*

Variables such as temperature, airbag condition, & other factors, may affect the performance of inflators

\* Only for Level 2

## SAFETY & WARNINGS

1. Always wear safety glasses with side shields which conform to ANSI standard Z87.1 or EN166.
2. Never use air source for cleaning.
3. Never exceed maximum operating pressure stated on the airbag.
4. Never point inflator or inflation device towards face or body.
5. Only use Shippers Products inflators to inflate airbags.
6. Do not submerge the airbag or inflator in water.
7. Store the airbag and inflator in a dry area. Do not operate or expose inflator to wet weather elements.
8. Failure to follow these safety instruction could result in serious injury.

## SHIPPERS PROMISE

### We'll be your lowest cost supplier by...

- **Lowering your total costs** by preventing damages and improving the arrival condition of your products
- **Increasing** your productivity
- **Simplifying** your purchases with the most extensive range of dunnage air bags and inflation devices in the industry

### We'll guarantee your satisfaction with...

- **The highest quality products** made in our own North American ISO9001 facilities
- Our commitment to on-going **product innovation and continuous process improvement**
- **On-site sales** and load planning assistance
- Supervised installation, loading procedures and safety training- custom **fit for your business**

### We'll be easy to do business with...

- The most **highly trained load securement specialists** in our industry
- Our **professional and responsive** customer service teams
- **Fast shipping** from stock in our North American facilities
- The capability to **lower your supply chain risk**

**Please contact Customer Service or Sales Representative if you have any questions.**